

Post-Lewinnian Analysis: from Pitch Perception to Music Analysis

Jun-ichi TAKAHASHI ¹

¹ 8-3-5 Nagaura-ekimae Sodegaura, Chiba, 299-0246, Japan

e-mail: takajun@joy.ocn.ne.jp

Abstract

Harmony is a fundamental concept in Western music theory, and its number-theoretical structure has been studied since ancient Mesopotamia. The relationship between music and mathematics has become stronger in recent years, leading to two questions: What is the reason for this connection? How can the mathematics of Western music theory be applied to other musical traditions? This article approaches these problems using the recently developed theory based on the group-theoretic description of pitch perception, where the perceptual structure of acoustic signals, represented by tetrahedral homology, is produced under the survival strategy exploiting acoustic signals. Here the constraints of a single source and temporal coincidence in the pitch perception are relaxed, and essential elements of music such as scales, chords, and chord progressions are discussed within a unified framework of Sound Integration. Musical analysis of six pieces from different genres is used to test the idea. Through these considerations, it is shown that homology in group-theoretic structures helps to understand so-called 'ambiguous tonality'. The theory presented here provides a useful basis for understanding the mathematical structure of harmony in music perception.

Keywords: Pitch perception, Sound Localisation, Auditory Scene Analysis, Sound Integration, Homology

1. Introduction

The modern theory of harmony, including consonance and dissonance, triads, octave equivalence, inversion of chords, major and minor, root note bass and harmonic progressions, and cadences, is said to have been created by Jean-Philippe Rameau in the early eighteenth century (Rameau 1722). According to Dahlhaus, tonality was invented by François-Joseph Fétis in the nineteenth century (Dahlhaus 1990). He discussed the historical development of harmony and defined tonality as the culturally produced simultaneous or successive relationship that exists between sounds (Fétis 1844). In Dahlhaus's book, three questions were raised. (1) Is a natural foundation of harmonic tonality possible? (2) Are only chordal relationships tonal, or should one also describe as tonal pitch relationships not based on chords? (3) Is the centering of relationships on a tonic pitch or triad an essential feature of tonality? At the end of the nineteenth century, Hugo Riemann produced the theory of functional harmony (Riemann 1875). While the theory of functional harmony gave a principal trend of subsequent music theory, the dualism of perception of overtones and undertones that he proposed to explain the major and minor modes received fierce opposition and he himself had to drop the idea of undertone perception (Riemann 1891, 1905). In the twentieth century, atonal music that intentionally eliminated Tonicity inherent in functional harmony emerged, such as serialism by Schoenberg. In the second half of the century, the pitch class set theory focusing on the set-theoretic structure of twelve-tone music was established by Milton Babitt, Allen Forte, and others (Babitt 1961, Forte 1973). The algebraic treatment revolutionised music theory since Pythagoras where sounds are treated numerically as frequency ratios. In the 1980s, David Lewin paid his attention to the perfect fifth and major third consonance relationships under octave equivalence. He redefined major and minor triads as geometric relationships on the Tonnetz and

Post-Lewinnian Analysis

succeeded in giving new mathematical meaning to dualism. His chord progression theory, which was redefined as group-theoretical mathematical operations, was called transformation theory and proved useful in analysing music using chords that could not be explained by functional harmonies, such as Romantic music (Lewin 1982, Cohn 1998). However, the perception of undertones has not been formally accepted to date.

The simultaneous or successive relationships that exist between sounds have been summarised in elaborate mathematics. There is no doubt that the mathematical approach has played a significant role in understanding music. However, does the contemporary mathematics in music treat music adequately? Music itself is never a mathematical construct divorced from its source in the human mind (Wiggins 2012). For example, analysis of the microtonal music based on Western music theory resulted in non-harmonic reconstruction into the tuning system of Persian and Indian music, such as the introduction of mathematically defined quarter tones and equal temperament. Is mathematical sophistication, especially in the equal temperament, at odds with the subjective value of the sound of the just intonation (JI)? There would be a need for some physiological mechanism that links the rich achievements in music mathematics with cognitive processes.

In this article, we investigate the mathematical structure of harmony based on biophysical processes in the perception of acoustic signals. While vision captures the spatial distribution of light rays emitted from an object onto the two-dimensional receptive fields of the retina, acoustic signals can only be perceived as time-varying frequency information. How do we distinguish the sound emitted by an object from randomly superimposed acoustic signals? The process of forming an accurate mental representation in the brain of individual sounds is called Auditory Scene Analysis (ASA) (Bregman 1994). The operation of reconstructing the acoustic object on the map

Post-Lewinnian Analysis

in the brain by segregation and integration of the auditory elements is called Sound Localisation (SL). While there are various opinions on whether the origins of music are innate or cultural, it is natural to assume that the ASA as a survival strategy underlies music that is a structured acoustic signal perception (Trainor 2015). Recently, under the SL in ASA, a model was proposed in which pitch perception arises from reinforcement learning in the Neuronal system using perturbative nonlinearity in cochlear (Takahashi 2023a). We reconsider the constraints of the pitch perception model to provide a neurobiological foundation for the abstracted mathematical structure of harmony and reinterpret Lewin's idea of transformation which is called Neo-Riemannian theory (NRT). We exemplify musical analysis with the post-Lewinnian treatment of harmony in various genres of music.

2. Pitch Perception Model

In the first section, we summarise the model of the evolution of pitch perception discussed in the reference (Takahashi 2023a, 2023b). Consider the meaning of acoustic signal perception in the survival strategy of living organisms. Living organisms react to changes in physical or chemical quantities in the external environment and change their behaviour. Hearing is a perception that targets the elastic deformation of the atmosphere in the range of about 20 to 20 kHz. We use acoustic signals emitted from the object as a trigger signal to determine whether to escape from or approach the object. To do this, it is necessary to segregate the acoustic signal emitted from the sound source from the environmental sound, grasp the positional relationship between the sound source and us, and judge the meaning of the sound source. Vision has a two-dimensional detector, the retina, and spatial information is sent directly to the brain (strictly speaking, depth

Post-Lewinnian Analysis

information is reconstructed in the brain). Hearing has hair cells that are only linearly aligned sensors that detect intensity signals fluctuating in time on the frequency axis. Nevertheless, hearing provides a function of SL, localising acoustic objects on a virtual map in the brain, and providing received information of acoustic signals as triggers for action determination. Why are we able to segregate individual acoustic objects from complex environmental sounds? The simplest strategy is to focus on the musical tone structure, that is, the harmonic structure emitted by the acoustic object, and segregate and integrate the acoustic signal based on the temporal coincidence of the harmonics in the sound. Takahashi focused on the nonlinear characteristics of the cochlear amplifier associated with the amplification of small acoustic signals. The second and third harmonics, which are always synchronous with the fundamental, are used as teacher signals for reinforcement learning of coincidence detection. Because reinforcement learning is bidirectional for target signals and teacher signals, learning of $f - 2f$ and $f - 3f$ coincidences is accompanied by the learning of $\frac{1}{2}f - f$ and $\frac{1}{3}f - f$ coincidences. Therefore, even when teacher signals over 4th-order harmonics are not given, their chain enables learning of the coincidence of $f - 2^n f$ and $f - 3^m f$ (and $f - 2^n 3^m f$) for $n, m = -\infty$ to ∞ , which produces the power series harmonic template. At the same time, the third-order nonlinearity gives $2f_1 - f_2$ coupling and enables learning of $5f, 7f, 10f, 14f \dots$ harmonics coincidence with the fundamental by recursive use of elements in the power series harmonic template (table 1). On the other hand, the learning of the prime harmonics $11f, 13f, 17f, 19f \dots$ needs another recursive learning of $5f$ and $7f$ harmonics, which enhances the learning cost dramatically. As a result, the template has elements of all integers up to 10 and deficits at prime numbers over 11. This model can answer various problems in pitch perception such as missing fundamental, octave equivalence, undertone perception, pitch shift effect, etc. In

Post-Lewinnian Analysis

particular, the appearance of gaps in F_0DT at the 10th order can be explained by the deficits of the harmonic template over the 11th order, strongly supporting the validity of this model, which is difficult to explain by the simple position or time models of pitch perception.

It is noted that the harmonic template enables the perception of not only harmonics but also subharmonics. The perception of the subharmonics is nothing other than the perception of the undertones that Riemann aspired to (Riemann 1875). The subharmonics are hard to be generated by the perturbative nonlinearity. However, they are perceived because of information processing in the brain. The perception of the undertone is allowed as a psycho-phenomenon rather than a physico-phenomenon. As a result, pitch perception can be represented by a group generated from four prime numbers, 2,3,5, and 7. The elements are written by $2^n 3^m 5^p 7^q f_0$, where f_0 is the fundamental frequency and $n, m, p,$ and q are integers from $-\infty$ to ∞ . Here, the pitch has two meanings the absolute frequency and chroma relative to a note with the fundamental frequency f_0 . Hereinafter, the pitch is used in the latter meaning, and unless otherwise specified, f_0 is omitted and the pitch is expressed as a ratio to it. Although the pitch group has the order of ∞ , only a small set of elements in the group is available for perception due to the limitations of the finite cochlear filter bandwidth and the finite frequency resolution. A small set here means a set of elements with small absolute values of $nmpq$ among the elements $2^n 3^m 5^p 7^q$ of the group generated from $\{2,3,5,7\}$. This group corresponds to 7-limit JI. Generator seven had not been very common in Western classical music. However, as will be discussed below, the ambiguous tonality generalised since the nineteenth century is represented as an approximation of 7-limit JI by 5-limit JI. The blue notes in jazz, which are said to have originated in African music, have been noted to have frequencies of $7/4$, $7/5$, and $7/6$

Post-Lewinnian Analysis

relative to the root note (Kubik 2008, Cutting 2018). The 22 Shruti in Indian classical music was shown to be well approximated by 7-limit JI (Takahashi 2023b). It will be reasonable to assume that 7-limit JI is present in the basic structure of human acoustic perception. The pitch is calculated from the coincidence of harmonics emitted from a single acoustic object. Acoustic signals are simple elastic waves, so sound integration is possible even if there are multiple sound sources if they have a common fundamental frequency. If there is a common divisor between the pitches of musical tones with different pitches, all the tones are integrated under their common fundamental frequency. The group integration of two tones is the consonance, while the group integration of three or more tones is the chord. Unless otherwise specified, we will not distinguish the term consonance from the chord.

3. Representation of tone group

We introduce the following expressions for the tone group $(p_1, p_2, p_3 \dots)$, where p_i 's are frequency ratios with respect to the fundamental frequency. When the elements of the pitch group $\{2, 3, 5, 7\}$ are expressed as $2^n 3^m 5^p 7^q$ under a certain reference frequency (tonic note), it is named as the canonical form and its powers n , m , p , and q as the canonical index. Sound integration based on a strong correlation between pitches when the frequency ratio is a power of 2 is known as octave equivalence. Also, when the frequency ratio is a power of 3, we perceive strong consonance. This is known as the perfect fifth consonance. Folding into an octave corresponds to considering the factor group of modulo 2. When m , p , and q are given for the element of the factor group, n the power of 2 is uniquely determined under the octave equivalence. From now on, we treat the pitch group as a factor group of modulo 2. When p_i 's are rational

Post-Lewinnian Analysis

numbers, we call them a rational form (table 2). Since we discuss consonance relations under the tone group, we assume that a rational form is a canonical form. We reduce them to a common denominator or numerator. When all the numerators or denominators are 1, we call them a normal form. Unless otherwise specified, the number used for the reduction is not shown. If necessary, the number is written outside the bracket. As has been noted already, we allow the subharmonics perception. We attribute it to a minor mode. When p_i 's are written in decimal, we call them a decimal form. When the decimal form is approximated by the nearest integers or the nearest inverse of integers, we call them a proximate normal form. The decimal form varies with the tuning system. The proximate normal form is stable against the error associated with the tuning but need not necessarily be unique. What values are perceived may depend on the perception mode analytic or holistic, whether the error is tolerated, the integrated pitch is perceived, a partial consonance relationship is perceived, or no consonance relationship is recognised, and it is perceived as noise. The group of three notes (4,5,6) and $(1/4, 1/5, 1/6)$ are the major and minor triads that have highly consonant combinations of musical tones. A minor triad $(1/4, 1/5, 1/6)$ is written as a decimal form (4,4.8,6), which is written also as a proximate normal form (4,5,6). In the proximate normal form, the minor triad can be considered a frustrated major triad also. When all the powers of 2 in the normal form are reduced to 0, we call them a prime form. If the term 1 appears in the prime form, a number 2 would be written to indicate that we consider a modulo system of 2. Here, the term prime form is also used in pitch class set theory. The prime in it is derived from the primary. Our prime is named after the algebra of prime numbers. Remember that each 'prime' represents essentially the same irreducible representation of a tone group, but with a term specific to each expression.

Post-Lewinnian Analysis

In the chromatic scale with twelve tones, the graphical representation of the notes belonging to the scale, Tonnetz, is introduced by drawing attention to the remarkable cooperative relationship between the perfect fifth-degree and the major third-degree consonances. Tonnetz allows triads to be represented by triangles consisting of three adjacent vertices, and a chord progression to be represented by a transformation between the triangles. Placing the tones belonging to the subgroup $\{2,3,5\}$ of the $\{2,3,5,7\}$ sound structure on two-dimensional coordinates under modulo 2 with the powers of 3 and 5 as coordinate values yields Tonnetz (Euler's Tonnetz). It gives a map of a rational form of the 5-limit JI. In fig. 1, the y-axis is tilted to match the usual hexagonal grid representation. In the following, sound structure in harmonic space is discussed based on Tonnetz.

4. Harmony

In Western music theory, the frequency ratios $(1:3/2)$ and $(1:4/3)$ between two notes are called perfect consonant intervals of the perfect fifth-degree and perfect fourth-degree consonant interval. The ratios $(1:5/4)$ and $(1:5/3)$ are called major third degree and major sixth degree, $(1:6/5)$ and $(1:8/5)$ are called minor third degree and minor sixth degree. These four intervals are called imperfect consonance. Other combinations are classified as dissonant. When displayed on the Tonnetz, perfect consonances correspond to adjacent grid points on the 3-axis, and imperfect consonances correspond to adjacent grid points on the 5-axis or 5/3-axis. We define the degree of consonance (DoC) between two tones as (m_1-m_2, p_1-p_2) , where m_i and p_i are the canonical indexes of tones on the 3- and 5-axis on the Tonnetz. For example, the perfect consonance of perfect fifth and perfect fourth degrees is $(1,0)$, the imperfect consonance of major third and

Post-Lewinnian Analysis

minor sixth degrees is $(0,1)$, the imperfect consonance of major sixth and minor third degrees is $(1,1)$ and the tritone is written as a consonance interval expressed as $(2,1)$ rather than dissonance. The asymmetry of the perception of acoustic signals between the 3- and 5-axis, and their direction would produce an ordered structure of sounds based on DoC under ASA (Takahashi 2023b). For example, the Pythagorean scale, made up of subgroup $\{2,3\}$ of the pitch group, has an ordered structure known as the circle of the perfect fifth. The distance between tones is expressed as the number of steps on the circle between two tones. DoC is the cognitive tone distance through signal processing in the brain. The tone distance derived from the consonance relation is called the harmonic distance. On the other hand, in the auditory tract, tonotopies are transferred at all levels from the inner ear to the cortical auditory cortex, and physiologically the magnitude of the frequency gives the order structure of the sound, allowing the perception of tone distance by the ratio of frequencies. We name this tonotopical distance. In the brain, the perception of distance between tones would have a dual structure, physical (tonotopical) distance and cognitive (harmonic) distance.

The consonance relationship of three or more notes is called a chord. In 5-limit JI, triads are represented by triangles on Tonnetz. major triads with the normal form $(4,5,6)$ and minor triads with the normal form $(1/4,1/5,1/6)$ are translated to the prime form $(2,3,5)$ and $(1/2,1/3,1/5)$ by folding under octave equivalence. respectively. The major triads are upward triangles, and the minor triads are downward triangles which are inverted around the vertex 4 of the triangles each other on the Tonnetz. For tunings other than 5-limit JI, it is not always possible to place triads on the Tonnetz. Even in this case, the finite bandwidth of the frequency filter in hearing allows for a translation to 5-limit JI via the proximate normal form, thus enabling placement on the Tonnetz grid. The sound group mapped to the Tonnetz grid will be integrated into the pitch and

Post-Lewinnian Analysis

acquire a sense of consonance. Note that chords should be considered as an integrated musical tone rather than a combination of distinct tones. From the perspective of pitch perception, a chord is a tone group integration, providing the perception of a fundamental frequency (pitch) and a spectrum consisting of harmonics (timbre). Viewed differently, a chord can be regarded as a timbre decoration by controlling the spectral structure of a tone group characterised by pitch. The separation of pitch and timbre from the perceptual structure of sound would provide a bridge between Western classical music and spectral music, which includes not only contemporary music but also microtonal music in the non-Western world (Fineberg 2000, Chahin 2017).

The major triad chord (4, 5, 6) is a sequence of three consecutive overtones, which is integrated into a pitch by harmonic template matching. The value returned as the pitch is 1 corresponds to the root note of the major triad, which has the same chroma but two octaves lower. On the other hand, the integration of a series of undertones inevitably gives rise to an upper pitch root note. The minor triad (1/4, 1/5, 1/6) is integrated through subharmonic matching. The resulting pitch having 1 corresponds to the same chroma of the highest fifth note of the minor triad chord but is two octaves higher than it. We name the former the lower pitch root note and the latter the upper pitch root note of the triads. Hereinafter, chord names are written in bold italics to distinguish them from pitch root tones.

Krumhansl used the probe method to estimate the distances between the triads of a diatonic scale and mapped the chord distances to two-dimensional coordinates (Krumhansl, 1983, 1998). His assessment placed the I tonic, V dominant, and IV subdominant close together, with III, VI, and II far away from I and VII apart in a different direction. These positionings would be comfortable for musicians. However, why are III and VI tonic and II subdominant, yet III and II are placed in symmetrical

Post-Lewinnian Analysis

positions far apart across VI? When representing triads on Tonnetz, the six triads from I to VI occupy six adjacent triangles. Focusing on the integrated pitch, in the C major scale, I, IV, and V are major triads, and the pitch root notes are C, F, and G respectively, while II, III, and VI are minor triads and the pitch root notes are A, B, and E. We have introduced DoC instead of binary consonance and dissonance to evaluate the consonance relationship. On the Tonnetz, the DoC of F and G are $(\pm 1, 0)$ and one step on the 3-axis relative to the tonic C of the scale (fig.2a). The DoC of E is $(0, 1)$ and is one step on the 5-axis relative to C. The DoC of A and B is $(\pm 1, 1)$ and is one step on the 3-axis relative to E. The perceived distance per step on the 5-axis would be greater than the distance on the 3-axis. As the per-unit distances on the 3- and 5-axis are significantly different, then, C, F, G, and E, A, D would have been perceived as independent groups, while the F-C-G positional relationship would have been perturbatively added under the distance on the 5-axis to give a leveraged A-E-D positional relationship around E (fig 2b). The VII has an integrated pitch at F from the overtone series and another integrated pitch at B from the undertone series in the proximate normal form. The pitches are shifted out of the pitch group element due to a pitch-shift effect. This effect is a detuning and must be treated as a perceptual quantity separate from the distance between the consonance. This will be discussed again later.

Now consider the case where a major triad and a minor triad share vertices of a triangle on the Tonnetz corresponding to 3 and 5. The pitch classes of the pitches into which they are integrated have a semitone difference, but are four octaves apart, making sufficient separation difficult, and they will be perceived as if they were in unison (fig.3). We name it Triad Root Equivalence. When these two triads are played simultaneously, they form a major-seventh chord. It is a special tone having a certain pitch and a timbre of superposition of both an overtone sequence and an undertone

Post-Lewinnian Analysis

sequence. Milne et al. examined the distances between chromatic triads (Milne & Holland, 2016). As they showed, the distance between chromatic chords cannot always be explained by pitch root note distance alone (table 3). However, if limited to between major triads and between minor triads, the DoC is in the order $(0,0) < (1,0) < (0,1) < (1,-1) < (2,0) < (1,1) < (2,1)$, which can be explained by the competition between the accumulation of 3 and 5. Here, the $(1,-1)$ position assumes an offset on the 3- and 5-axis. On the other hand, the distance between the major triad and minor triad has a more complicated ordering, which strongly suggests that secondary integration is involved in addition to the distance between the root notes in the analytic perception of chords. We consider the specific proximity of C_m-Eb to be strong evidence that four-tone integration is more stable than the perception of two three-tone integrations separately, and another proximity of $C-E_m$ to be strong evidence that it is perceived as the unison of the two pitch root tones due to Triad Root Equivalence. On the other hand, $C-F_m$ is further away than C_m-Eb or even $C-E_m$, despite sharing a pitch root note. We name it Common Root Discrepancy. One possibility of these origins is the octave enlargement effect, where the physical octave becomes slightly larger than the subjective octave ($=2$) for a variety of tones (Ogushi 1983). He reported an enlargement of 0.4 ~ 2.6% per octave on average. Even though the data were strongly dependent on the listeners and scattering, it is consistent well in order with the Triad Root Equivalence. Bypassing the chord progression by such secondary integration makes the chord progression ambiguous and complicated, but at the same time creates rich diversity. The diverse progression paths would be reorganised under the holistic perception and form the backbone of the non-standard progressions in the transformation theory, as discussed below.

Post-Lewinnian Analysis

In the diatonic scale, there are seven types of triads: three major triads, three minor triads, and one diminished triad. Major and minor triads are represented by the common prime form (2,3,5) and (1/2,1/3,1/5) in 5-limit JI, respectively. The diminished triad is represented by the rational form (1,6/5,36/25) and the normal form (25,30,36). It has no simple prime form and cannot be embedded in a triangle on Tonnetz. However, because $(1,6/5, 25/36) = 6 \cdot (1/6, 1/5, 1/4.1666) = 6/25 \cdot (4.1666, 5, 6)$, it is represented by the proximate normal form (1/6,1/5,1/4) and (4,5,6). The approximation error to 1/4 and 4 respectively is 4.2%. Note that it is approximately the midpoint of the neighbouring semitones. We consider the diminished triad as a superposition of slightly out-of-tune major and minor triads flanking three notes of the diminished triad arranged on the 5/3-axis (fig.4a). Similarly, the augmented triad is represented by the rational form (1,5/4,25/16) and the normal form (16,20,25), which cannot be embedded in a triangle on Tonnetz, but written as $(1,5/4,25/16) = 25/4 \cdot (1/6.25, 1/5, 1/4) = 1/4 \cdot (4,5,6.25)$, so each is represented by the proximate normal form (1/6,1/5,1/4) and (4,5,6). The approximation error to 1/6 and 6 respectively is 4.2%. It also is represented by a pair of major and minor triads flanking three notes of the augmented triad arranged on the 5-axis (fig.4b). Note that the approximation of augmented or diminished chords to major and minor triads by the replacement of a tone with the nearest tone is equivalent to the parsimonious transformation in the Cube Dance (Douthett & Steinbach 1998, Douthett 2008).

When tones are placed at the vertices of a tetrahedron with vertices 2, 3, 5, and 7, the tetrahedron represents a tone group that is integrated at a pitch in 7-limit JI. The tetrahedra arranged in three-dimensional space by tone translation corresponds to the 3D-Tonnetz discussed by Gollin and Tymoczko (Gollin 1998, Tymoczko 2010). Gollin invented 3D-Tonnetz to extend the transformation theory from triads to tetrads. His

Post-Lewinnian Analysis

focus was on the relationship between dominant and half-diminished chords in the seventh chords. He noted that the notation of both in the neo-Hauptmann system was an extension of the major-minor relationship in the triad. Whereas the triad has intervals of four semitones (major third) and seven semitones (perfect fifth), the tetrad has a further ten semitone intervals. Corresponding to the Tonnetz axes given for the intervals of the triad, Gollin gave the tetrad a further ten-semitone unit axis, which gave the 3D-Tonnetz, and discussed the transformation theory under the geometric representation of the tetrahedron. Tymoczko also considered 3D Tonnetz like Gollin by extending the triad in 2D Tonnetz to a tetrad. He too focused on the relationship between the dominant chord and the half-diminished chord. In his case, he noted that both share a diminished triad and are in a symmetrical position, leading to 3D Tonnetz as a space that embeds tetrad through a topological deformation of 2D Tonnetz. Gollin's approach focuses on the geometrical symmetry of the pitch class set arrangement on the 2D Tonnetz, while Tymoczko's approach would have been homotopic, focusing on the continuous deformation from a 2D figure to a 3D figure. Our approach focuses on the purely algebraic relationship between number-ratio relations in the group-theoretic model of pitch perception, which assumes the existence of undertones. The overtone sequence of four consecutive integers (4, 5, 6, 7), like in the triads, is represented by a tetrahedron with vertices of 2,3,5,7. We attribute it to a proper major tetrad. The undertone sequence of four consecutive subharmonics ($1/4$, $1/5$, $1/6$, $1/7$) is represented by a tetrahedron inverted from the tetrahedron of the proper major tetrad around the vertex 4. We attribute it to a proper minor tetrad. Whereas the major and minor triads were represented in 2D Tonnetz by upward and downward triangles, the major and minor tetrads are represented in 3D Tonnetz by tetrahedra with vertices opposite each other with respect to the plane containing 4, 5, and 6. Each is integrated into a pitch under

Post-Lewinnian Analysis

template matching. As with triads, the pitch root is two octaves below the note corresponding to the vertex 4 for proper major tetrad and two octaves above the note corresponding to the vertex $1/4$ for proper minor tetrad, defining the pitch of the tetrads. As in the case of triads, both are tonal decorations of the pitch tone by means of an overtone or undertone sequence.

Consider the tetrad in 5-limit JI. As the number of tones increases from three to four, matching from the harmonic template is averaged out, which is likely to allow for better pitch integration even when the detuning in individual tones is large. Table 4 shows the normal form, decimal form, proximate normal form, and pitch root tones of various tetrads. Here, the tonic is taken at C ($1/1$).

- C_7 and C_{m7b5} are approximated by a proper major tetrad and a proper minor tetrad with the template (4,5,6,7) and ($1/4, 1/5, 1/6, 1/7$), the root notes of which are C and B \flat , respectively. The errors are 3% at 7.2 for 7. Each chord may be written in another decimal form of a proper minor tetrad or a proper major tetrad. However, those representations have greater errors in template matching than the original, so they are discarded.
- $C_{maj7\#5}$ and $C_{m(maj7)}$ also are approximated by the proper major and minor tetrads with the root notes C and B, respectively. The maximal errors are 4% at 4.8 for 5, and 3.84 for 4.
- C_{maj7} is written by the obvious decomposition of a superposition of the major triad $1/4*(4,5,6)$ and the minor triad $15/2*(1/4, 1/5, 1/6)$ as the approximation to four-tone integration results too large error. As already mentioned, each triad is integrated into a note with the same chroma of its root note but two octaves below and a note with the same chroma of its highest fifth note but two octaves

Post-Lewinnian Analysis

above, respectively. The pitch classes of the two are almost in unison, as they differ in pitch class by a semitone but four octaves in pitch.

- C_{m7} is also a superposition of the major triad and minor triad. However, it has an approximation of a consecutive four integers with errors of 4% error at 4.8 for 5 and 3% at 7.2 for 7. It has two proximate normal forms $1/4*(4,5,6,7)$ and $36/5*(1/4,1/5,1/6,1/7)$. Four-tone integration will take precedence over double three-tone integration in harmonic template matching as shown in table 4. It should be noted that the distance between the two pitch root notes is small even though their interval is a whole tone as that of C_m-Eb in table 3.
- C_{dim7} has a variety of approximations to the proper tetrad (table 5). It is noted that all four notes have the potential to be the root note even though the error reaches up to 7.4% at 5.556 for 6 in the second group and 8% at 4.32 for 4 in the first group, whereas those in other groups are within 5%, which would be acceptable barely because more tones are available for matching than in a triad. The composer may choose the root note from any four notes in the chord as far as they allow the out-of-tuning. Which is the root will depend on the interrelation with the adjacent phrases rather than the chord itself.
- C_{7sus4} has approximations to $(4,5,6,7)$ and $(1/4,1/5,1/6,1/7)$ (table 6). The relatively large errors of 6.7% at 5.333 for 5 and 1/5.333 for 1/5 would be acceptable barely because more tones are available for matching than in a triad.

4. Chord Progression

Pitch perception is a sound group integration based on number-theoretic correlations and temporal coincidence in sound groups emitted from a single source. Relaxation of

Post-Lewinnian Analysis

the single source constraint gives rise to chords. Instead, it is possible also to relax the constraint of temporal coincidence, which gives rise to scales, chord progression, and voice-leading as the relaxation time of acoustic perception is finite. From its perspective, a chord is redefined as a pitch decorated with a timbre and a chord progression is a pitch progression accompanied by a timbre having a well-defined and variable spectral structure. We can understand a piece played by a piano, a violin, and a humming as the same music, not because we perceive the piano piece, the violin piece, and the humming piece separately and integrate them as the same music. We perceive the pitch progression and the timbre separately. Otherwise, we would not be able to perceive that they are the same piece of music when we use new instruments whose timbre we do not know.

Transformation theory has made a significant contribution to analysing the ‘ambiguous’ tonalities of Romantic music of the nineteenth century, which could not be explained by the functional harmony theory. However, it has not necessarily succeeded in clarifying the meaning of the tetrads, which is the central issue of the ‘ambiguous’ tonality. Extensions of transformation theory to tetrad have been made by introducing 3D Tonnetz (Gollin 1998, Tymoczko 2010), and extending parsimony to four-tone sets (Douthett & Steinbach 1998). In both methods, however, transformations between tetrads could be defined in an analogous way as between triads, nevertheless, these methods did not guarantee path consistency in transformations between triads and tetrads, as Hook pointed out (Hook 2007). Instead of transformations in pitch space, Hook considered cross-type transformation in the Generalised Interval System (GIS) space. Popoff et al. considered another approach of the category-theoretic PK network theory loosening the definition of transformation between triads and tetrads (Popoff et.al. 2018).

Post-Lewinnian Analysis

Here, one question is presented. The concept of parsimony has been used effectively in Transformation theory. Parsimony is given the meaning of nearest-neighbour transformation at a harmonic distance by a minimal procedure in three-tone pairs, but it must be assumed that the three tones are perceived independently. The superposition of three consonant tones is only a harmonic series with a common fundamental frequency from the view of acoustic perception. Why can one tone be easily separated from the others? The pitch perception model derived from ASA's SL separates chords into pitches and tones and maps chords onto the pitch space. The pitch space has a dual structure of harmonic and tonotopic space, with perceptual distances in each space. At the same time, timbres provide exceptional proximity, such as maj7 and min7. We reconsider and extend Lewin's transformation theory by means of the pitch perception model.

The NRT has three basic transformations of P, R, and L. In our model, we have a transformation class that acts on pitch and a transformation class that acts on timbre. The former is a translation on Tonnetz, with a 3-axis translation T and a 5-axis translation F, where T^{12} and F^3 are regarded as the identity under octave circularity. Our model accepts the undertone perception, and it has the interchange I between overtones and undertones and the cardinality transformation C_{ij} representing the transformation from cardinality i to cardinality j. In NRT theory, the transformations act directly on the triads and are written as $P=TI$ or $T^{-1}I$, $R=FI$ or $F^{-1}I$, $L=FTI$ or $(FT)^{-1}I$. The chord progression is given by the chain of transformations between neighbouring chords on Tonnetz. In our model, the perception of harmony implies finding tones that can be integrated into a pitch under the group structure of $\{2,3,5,7\}$. For a tone group with temporally fluctuating combinations, matching of major or minor chords and triads or tetrads is performed under template matching, and the successfully matched tones are

Post-Lewinnian Analysis

integrated into pitches and mapped onto Tonnetz. This operation is represented by I , C_{31} , and C_{41} . Integrated pitches can be recursively integrated with other pitches. The strength of integration decreases as the cardinality decreases, with integration between two tones being the weakest. Under the weak link between pitches, the pitches can take an excursion from pitch to pitch on the Tonnetz by translations F and T . In tonotopic space. On the other hand, the intervals between adjacent notes in the diatonic and chromatic scales are whole or semitone, where one-step translation on Tonnetz is impossible. We extend the translational transformation by continuous paths on Tonnetz to allow second-order transformations (whole tone= T^2 or T^{-2} , semitone= FT or $(FT)^{-1}$) and a third-order transformation (T^2F) for the tritone. This extension may seem opportunistic, but the order corresponds to a reduction in consonance and is significant as an extension. The tone progression in the tone space is described by a continuous path with timbre alteration between pitches that has up to a third-order jump on Tonnetz. This path corresponds to a generalisation of the chain of PRL transformations on Tonnetz in NRT. It should be noted that the one-step transformation in the $5/3$ -axis direction is a second-order transformation for F and T . According to Fig. 4, the distance is smaller than $DoC=(2,0)$ or $(1,1)$ and then closest to a first-order transformation, making it meaningful to draw Tonnetz in oblique hexagonal coordinates rather than Cartesian quadratic coordinates. At the same time, since bass arpeggiation in Schenker theory corresponds to the C_{n1} operation and linear progression is a continuous path between pitches including quadratic transformations, the continuous path between pitches in our model can be considered a generalisation of the *urlinie* in Schenker theory. In the following chapter, we present examples of musical analysis of our model.

5. Examples of Analysis

5.1 Beethoven's Ninth Symphony, mm 143-176

It is a typical example of LR chains (Cohn 1997, Mason 2013). We consider the underlying dynamics behind the chain progressions from the view of the pitch perception model. Its chord progression is the following (fig.5).

C-A_m-F-D_m-Bb-G_m-Eb-C_m-Ab-F_m-Db-Bb_m-F#-Eb_m-B-Ab_m-E-Db_m-A

It progresses in the negative direction on the 3-axis, alternating between major and minor triads. Each triad is rewritten to the pitch root note.

C-e-F-a-Bb-d-Eb-g-Ab-c-Db-f-F#-bb-B-eb-E-ab-A

The uppercase letters are the pitch roots of the major triad, and the lowercase letters are those of the minor triad. Consider the following grouping of notes.

(C-e)-(F-a)-(Bb-d)-(Eb-g)-(Ab-c)-(Db-f)-(F#-bb)-(B-eb)-(E-ab)-A

Each motion in the brackets is a one-step shift in the upward direction on the 5-axis. At the same time, the motion between brackets does not change the pitch class due to the Triad Root Equivalence. Therefore, the motion is monotonous upward tone motion on the 5-axis, alternating timbre mode. On the other hand, when L is applied to a minor triad, the root note of the minor triad moves from the upper right vertex to the lower left vertex of the parallelogram consisting of the major and minor triads. At this time, the pitch class can be regarded as unchanged due to Triad Root Equivalence. Equation of the tone progression can therefore be written as follows with changing the brackets.

C-(f'-F)-(bb'-Bb)-(eb'-Eb)-(ab'-Ab)-(db'-Db)-(f#'-F#)-(b'-B)-(e'-E)-(a'-A)

Here, ' indicates rewrite by Triad Root Equivalence. The motion is monotonous negative motion on the 3-axis, alternating timbre mode. The LR chain is a mixture of these two motions.

5.2 Brahms' Concerto for Violin and Cello, Op. 102. In mm 270-178

It is a typical example of LP chains (Cohn 1997, Mason 2013). Its chord progression is the following (fig.6).

Ab-Ab_m-E-E_m-C-C_m-Ab-Ab_m-E

Each triad is rewritten to the pitch root note as the following.

Ab-eb-E-b-C-g-Ab-eb-E

It is written in two forms under Triad Root Equivalence.

(Ab-eb)-(E-b)-(C-g)-(Ab-eb)-E

Ab-(e'-E)-(c'-C)-(ab'-Ab)-(e'-E)

The former is the monotonous positive motion on the 3-axis, where the motion within the brackets is the stepwise motion on the 3-axis with alternating the timbre mode and the motion between brackets does not change the pitch class due to the Triad Root Equivalence. The latter is the monotonous downward motion on the 5-axis, alternating the timbre mode. The LP chain is a mixture of these two motions.

5.3 Liszt's Grande Fantaisie Symphonique für Klavier and Orchester, mm. 185-199

It is a typical example of SL chains, including the secondary transformation of S=RPL=LPR (Mason 2013). Its chord progression is the following (fig.7).

Bb_m-A-Db_m-C-E_m-Eb-G_m-F#-Bb_m-A-Db_m

Each triad is rewritten to the pitch root note as the following.

f-A-ab-C-b-Eb-d-F#-f-A-ab

It is written in two forms under Triad Root Equivalence.

(f-A)-(ab-C)-(b-Eb)-(d-F#)-(f-A)-ab

f-(Ab'-ab)-(B'-b)-(D'-d)-(F'-f)-(Ab'-ab)

Post-Lewinnian Analysis

The former is the monotonous upward motion on the 5-axis, where the motion in the brackets is the stepwise motion on the 5-axis with alternating the timbre mode and the motion between brackets does not change the pitch class due to the Triad Root Equivalence. The latter is the monotonous downward motion on the 3/5-axis, alternating the timbre mode. The SL chain is a mixture of these two motions. The readers will see other examples of chained PRL transformations in the reference (Mason 2013).

5.4 Take A Bow from Muse

It is an example of the non-standard transformation of chord progression having augmented triads (Popoff et.al. 2018). Its chord progression is the following (fig.8).

D-D_{aug}-G_m-G-B_{aug}-C_m-C-C_{aug}-F_m-F-F_{aug}-B_b_m

This chord progression cannot be treated by PRL transformation. Popoff et.al. analysed it by extending the PRL network structure and introducing new transformations *UPL*. Here, we discuss the same passage by the duality of the augmented chord under the pitch perception model.

The underlying duality of the augmented triad creates a new progression form that switches progressively via a mixed state. For example, ***Ab_{aug}*** contains a pair of minor and major triads (***A_m***, ***Ab***). When ***Ab_{aug}*** is inserted between ***A_m*** and ***Ab***, the abrupt change from minor to major tones can be mitigated via a mixed state of major and minor tones. In addition, since the inverted forms of ***Ab_{aug}***, ***C_{aug}***, and ***E_{aug}***, contain the pairs (***A_m***, ***Ab***), (***Db_m***, ***C***), and (***F_m***, ***E***), ***Ab_{aug}*** functions as a buffer in the progression from either ***F_m***, ***A_m***, or ***Db_m*** to ***E***, ***Ab*** or ***C***. This function is nothing other than Doothett's Cube Dance (Doothett & Steinbach 1998, Doothett 2008). Remember that parsimony and proximity are equivalent, so it is trivial that they become the same operation, but parsimony links each triad with OR, a selection of one of them, whereas proximity links

Post-Lewinnian Analysis

it with AND, a mixed state of them. Decomposing the augmented chord in the chord progression yields the following equation.

$$D-[D/Eb_m]-G_m-G-[G/Ab_m]-C_m-C-[C/Db_m]-F_m-F-[F/F\#_m]-Bb_m$$

Here [*/*] indicates that two triads coexist, and B_{aug} is inverted to G_{aug} . Rewriting each triad as root notes yields the following equation.

$$D-[D/bb]-d-G-[G/eb]-g-C-[C/ab]-c-F-[F/db]-f$$

This is a superposition of the following two progressions.

$$(D-D-d)-(G-G-g)-(C-C-c)-(F-F-f)$$

$$(D-bb-d)-(G-eb-g)-(C-ab-c)-(F-db-f)$$

The former is a negative motion on the 3-axis of a single note with alternating timbre mode. The latter is a negative motion on the 3-axis together with the former while reciprocating on the 5-axis. If one separates it as the following, it is shown that the progression is not only a translation on the 3-axis of the three-tone units but also that the inter-measure progression is promoted via a minor triad cycle.

$$D-(bb-d-G)-(eb-g-C)-(ab-c-F)-(db-f)$$

5.5 Coltrane's Giant Steps

We take Giant Steps of Coltrane, which is known as a culmination of multi-tonic systems. Giant Steps has a very logically constructed chord progression. As Capuzzo discussed Martino's theory (Capuzzo 2006), there are numerous connections between Giant Steps and NRT, but it is not always easy to explain by means of transformation theory. McClimon used the representation of the transformation graph to give an elegant account of the transformational structure of II_7-V_7-I , which plays a significant role not only in Giant Steps but also in Jazz in general. However, his argument imposed the

Post-Lewinnian Analysis

strong restriction of restricting tetrads to the pitch classes having three tones, at the expense of generality (McClimon 2017).

We discuss the transformational structure in Giant Steps using the sound integration model in pitch perception theory. The chord progression is the following.

***B_{maj7}-D₇-G_{maj7}-B_{b7}-E_b_{maj7}-A_{m7}-D₇-G_{maj7}-B_{b7}-E_b_{maj7}-F_{#7}-B_{maj7}-F_{m7}-B_{b7}
-E_b_{maj7}-A_{m7}-D₇-G_{maj7}-D_b_{m7}-F_{#7}-B_{maj7}-F_{m7}-B_{b7}-E_b_{maj7} D_b_{m7}-F_{#7}***

After descending the major third cycle of the maj₇-7 repetition from ***B_{maj7}*** to ***E_b_{maj7}***, the cycle is passed to the next descending cycle from ***G_{maj7}*** to ***B_{maj7}*** via II₇-V₇ progression of ***A_{m7}-D₇***. Thereafter, the ascending major third cycle of the II₇-V₇-I motion goes from ***F_{m7}*** to ***F_{m7}***, before reaching the II₇-V₇ of ***D_b_{m7}-F_{#7}***. The frequency ratio of the maj₇ chord is 1/1:5/4:3/2:15/8. As already mentioned, it is represented as a superposition of two chords, the major triad 1/4*(4,5,6) and the minor triad 15/2* (1/6,1/5,1/4) with two pitch root notes equivalent to the root and seventh note (fig. 9). The m₇ chord, which is II₇ of the II₇-V₇ chord, has two approximate representations of the major and minor tetrads under the frequency structure $1/1:6/5:3/2:9/5 = 4:4.8:6:7.2 = 1/7.2:1/6:1/4.8:1/4$, as already mentioned (fig. 9). As a result, the II₇-V₇ chord provides a pathway with the two pitch root tones of II₇ as the entry points and the pitch root tone of V₇ as the exit point via the perfect fifth and perfect fourth degrees from the II₇. We call this the Dual Entry Dominant System (fig.10). The chord progression of Giant Steps is described by the two pitch root note progressions shown in fig. 11. The first progression consists of a linear progression on the 5-axis in the first half. It progresses one major third step at a time upwards on the 5-axis starting at bb with a timbre alternation of minor three-tone integration and major four-tone integration, and cycles through the octaves three times before reaching 11th chord units, where the second cycle involves I-V-I (d-A*-D*) in II₇-V₇. It should be pointed out that the step-by-step pitch root progression ascends on

Post-Lewinnian Analysis

the 5-axis in the harmonic space whereas the chord descends on the 5-axis. The second half ascends one major third step upwards on the 5-axis, repeating I-V-I under the timbre alternation of minor three-tone integration, major four-tone integration, and major four-tone integration, starting from bb , returning to bb , and ending by cycling the minor triad, B_m . The second progression consists of descending major third cycles with a repetition of the (5,3) and (3,2) consonance in the first half, starting at B, reaching Eb , then going backward one step on the 5-axis via the root note g^* of II_7 , crossing the octave a total of two times repeating the (5,3) and (3,2) consonance again from G and reaching B. In the second half, the I-V-I ascends one major third step upwards on the 5-axis, repeating the timbre alternation of the minor four-tone integration, major four-tone integration, and major three-tone integration, starting from d, returning to d, and ending by cycling the major triad, B . In each case, if we focus on the pitch root notes, they are connected by a continuous path connecting the grid points on Tonnetz step-by-step. This shows that, under the pitch perception theory based on Sound Integration, Giant Steps is written definitely by chains of transformations of chords, each chord of which is represented by a pitch accompanied by a timbre.

6. Geometry in Harmony

6.1 Simplicial Complex

We have shown that the post-Lewinnian treatment (step-by-step transformation of chord) under the concept of sound group integration of pitch perception of the progression in NRT is successful in describing the progression of not only triads but also tetrads in a unified way.

Post-Lewinnian Analysis

Let us now summarise our mathematical framework. Consider a basic tetrahedron H_0 with 2,3,5,7 as vertices with the canonical index as the coordinate axis. The elements $2^n 3^m 5^p 7^q$ of the pitch group $\{2,3,5,7\}$ can be assigned to the grid points of the lattice given by the translation of H_0 . Mapping a pitch class to each lattice point gives the 3D-Tonnetz given by Gollin and Tymoczko. From this tetrahedron, a chain of simplicial complexes is created to form a homology group (Bigo et.al. 2014). In fig. 12, the homology of consonance relationships with a tonic C generated from the pitch group $\{2,3,5,7\}$ is shown. C_3 is the tetrahedron made of the four-tone integration, and C_2 , C_1 , and C_0 denote the figures created by 3, 2, and 1 vertex, respectively. ∂C_n is the boundary operator and gives a homomorphism from C_n to C_{n-1} . C_2 contains the subgroups $\{2,3,5\}$, $\{2,3,7\}$, $\{2,5,7\}$, and $\{3,5,7\}$ of the pitch group. C_1 does $\{2,3\}$, $\{3,5\}$, and so on. Not all the elements of the subgroups but only a small set of each can be perceived under the limitation of acoustic physiology. The small set generated from $\{2,3\}$ in C_1 yields the Pythagorean scale, and the small set generated from $\{2,3,5\}$ in C_2 yields the 5-limit JI. We note that $\{2,5\}$ yields a whole-tone scale and $\{2,7\}$ may provide the simplest prototype of the Slendro scale, often cited as an example of the five-note equal temperament (Polansky 1985) (table 7). The result of the cluster analysis of the musical tones in the Shruti system of traditional Indian music played by professional players could be well represented by $\{2,3,5,7\}$ (Datta 2011, Takahashi 2023b). $\{3,5,7\}$ yields a tridecatonic scale having a tritave (1:3) circularity, which is known Bohlen-Pierce scale (Müller 2020). $\{3,5\}$ gives its Pythagorean version, with the sequence of intervals 3:5 wrapping into tritave. $\{5,7\}$ may yield a pentatonic scale having nearly two and a half octave (1:5) circularity (“pentave equivalence”).

All simplicial complexes can be oriented. The oriented tetrahedra represents the proper major and minor tetrads, and the oriented triangles in $\{2,3,5\}$ represent the major

Post-Lewinnian Analysis

and minor triads. Orientations can be introduced in the same way for other simplicial complexes. These naturally introduced orientations will give a generalised major-minor tonality in the consonance relationship. Each simplicial complex has a homomorphism to a pitch through sound integration by harmonic template matching. Homology class classified by pitch gives a timbre. As a result, the tonsystem is represented by a fibre bundle with the group of simplicial complexes as the base space and the timbre as the fibre. One could consider formally JIs containing 11 or more primes and chain to C_4 or higher, but in terms of acoustic physiology, the generators are closed at four (Takahashi 2023a). Thus, ninth and larger chords will be perceived via morphisms to tetrad, triad, and dyad by the proximity under the pitch perception model. Under the homology picture, C_7 and C_{m7b5} are represented by the embedding of the proper tetrads into the group generated by $\{2,3,5\}$. We write it $C_3 \rightarrow C_2\{2,3,5\}$. It is a connection between different simplicial complexes via proximity. Similarly, $C_{maj7\#5}$ and $C_{m(maj7)}$ give other embeddings of $C_3 \rightarrow C_2\{2,3,5\}$ (table. 4). In the $C_3 \rightarrow C_2\{2,3,5\}$ embedding in diminished seventh chords, the root note and major/minor mode are degenerate in the pre-image (table 5).

The finite frequency resolution in hearing generates proximity between independent simplicial complexes, and the group acting on C_n allows transformation between different simplicial complexes under proximity. The proximity enables new chord progressions as if the space were connected by a wormhole, making possible a warp. We point out that homotopy would be necessary to be introduced to describe the embedding of such local structures into the global structure. The discussion of the homotopy structure of harmonies is a future task. Western classical music consisting of major triads is represented by C_2 , while music containing a seventh chord is represented by the direct product of C_2 and C_3 . Do kinds of music expressed in C_1 and C_0 exist,

then?

6.2 Non-Harmonic Integration

Koizumi proposed the tetrachord theory of the sound structure of Japanese traditional music (Koizumi 1958). Japanese traditional music possesses all notes corresponding to pitch classes other than the minor fifth for the twelve-tone scale. Nevertheless, there, the sound combinations are limited and broken down into independent pentatonic scales for performance. We consider his tetrachord would be a typical example of the sound structure in C_I .

Koizumi's tetrachord is not a series of four notes, but a set of three tones, with the two tones separated by fourth degree (frequency ratio 3:4) as the nuclear tones and the intermediate tones between them. The position of the intermediate tones corresponds approximately to the twelve equal temperament or 5-limit JI, so there are four tetrachords (fig.13a). The scales consist of conjunctions and disjunctions of the two tetrachords (conjunct scale is not popular). Koizumi's tetrachord theory successfully explained why Japanese traditional music has four pentatonic scales. Example 1 is the score of the lullaby of Itsuki village. It is a piece of example of Koizumi's tetrachord theory, where the tetrachords are the fundamental units for musical integration. The tetrachords of this piece are pairs of nuclear tones (A, D) and (E, A). Each tetrachord has F and B \flat as intermediate tones, forming the Miyakobushi scale A, B \flat , D, E, F, and A. The intermediate tones in this piece appear in pairs (F A), (B \flat A), and (B \flat D), where they act as decorated nuclear tones. The intermediate tones are classified as nonharmonic tones in Western music theory. The position of the tetrachord triads on the Tonnetz shows that the intermediate tones are not only tonotopical midpoints to the nuclear tones but also the nearest points in harmonic distance to the two neighbouring

Post-Lewinnian Analysis

nuclear tones, avoiding perfect fifths and major third consonance (fig.13b). They act as decorations, not by controlling the spectral structure of the tone integration through template matching, but through a non-harmonic fluctuation of the tone in frequency. The tetrachord progression becomes a motion between the three nuclear tones A, E, and D, which would correspond to I-IV-V in Western music. In NRT, the major triad and minor triad are the basic elements of sound structure. The triads are pairs of three tones with a frequency ratio of 4:5:6 or their inversion form, which undergo sound integration at C_2 in the pitch perception model. On the other hand, as Koizumi's tetrachord is represented on Tonnetz, the pairs of nuclear tones are adjacent to each other on the 3-axis. The intermediate tones are adjacent to the nuclear tones but do not form a triad. By using the tetrachord as the basic element of the sound structure instead of the triad, the three-tone integration at C_2 is avoided and the sound group integration is limited to the two-tone integration between the nuclear tones at C_1 . The disjunction of two tetrachords forms a pentatonic scale covering an octave. Focusing on the tonic notes in the octave, the frequencies of the nuclear tones of the two tetrachords are $1/3 \bmod 2$ and $3 \bmod 2$ with respect to the tonic, respectively. As already mentioned, the perception of harmonics corresponds to the generalised major mode and the perception of subharmonics corresponds to the generalised minor mode, so the scale produced by the disjunction of the Koizumi's tetrachords is tonally degenerate.

Why is the tetrachord given such a structure so that it avoids the tone group integration at C_2 (and the integration is closed at C_1)? We propose the following two hypotheses. Our first hypothesis is that the tone group integration at C_2 should be avoided to keep the purity of the individual tones in the perception of consonance relationships because it would result in the perception of new tones different from what is heard (missing fundamental). Such a phantom sound would be an unnecessary artifact

Post-Lewinnian Analysis

in ASA. It is shown that the attitude of avoiding the chordal harmony exemplified here is observed in Chinese traditional music, where recognition of the “opposite” comparativism between Western and non-Western music is discussed in the context of decolonialism (Zhuqing 2021). On the other hand, the progression would be boring with only nuclear tones. Our second hypothesis is that the placement of intermediate tones is a timbre decoration other than the harmonic structure control in the sound integration, which is independent of the progression of the nuclear tones. The dual structure of intertone distance is used to place tones with a low DoC and a small tonotopical distance from the nuclear tones to add fluctuations in the sound. This tone decoration creates a change of sonority in the progression between the tetrachords, which are restricted to the perfect first degree and the perfect fifth degree. Japanese traditional music is often played in the melisma style. The style preference may also come from a preference for tonal modification in tonotopical measure rather than harmonic measure.

Now, is there music represented by C_0 ? Percussion music without pitch is it, maybe. We would like to list rap music and Taiko performances separately. Historically speaking, it was not until the mid-twentieth century that they became established as an independent genre of music. We point out that it was after the establishment of the atonal music, which neutralised the tonality. We suspect that they are descendants of tonal music derived from the atonal music rather than a mere return to the rhythmic music.

In summary, we have shown that all number-ratio harmonic structures that constitute music, such as scales, chords, and chord progression can be described by mathematical structures using tetrahedral homology. The dynamics of music are governed by the dual structure of acoustic perception with physical (tonotopical) and cognitive (harmonic) measures, both of which we can consider biological origins. If we

Post-Lewinnian Analysis

call the simultaneous or successive relationship that exists between sounds a tonality, we would be able to consider that it was created by a survival strategy rather than culture, even if the choice of structure is determined by culture.

7. Conclusion

This paper considered harmony and harmonic progression in tonal music based on a tetrahedral homology model, which is based on the pitch perception model derived from the reinforcement learning in the Neuronal system using perturbative nonlinearity in the cochlear amplifier, where sounds are segregated and integrated using the harmonic structure of sounds as cues for SL in ASA. Acoustic signal perception is processed by tone group integration with harmonic template matching generated from the pitch group with four prime numbers (2, 3, 5, and 7) as the generators, and as a result of the processing, chords are decomposed into the product of pitch and timbre. This model provides the mathematical and neurobiological basis for the embedding of triads and tetrads into Tonnetz. By separating timbre from chords, it is possible to consider chord progressions independently of cardinality. Several pieces from Romantic music, jazz, and Japanese traditional music were chosen and their transformation-theoretic progressions of harmony were analysed. Our answers to Dahlhaus' three questions about tonality are (1) Is a natural foundation of harmonic tonality possible? YES. In our model, harmonic tonality is not a product of acoustic perception but a survival strategy of SL in ASA. (2) Are only chordal relationships tonal, or should one also describe as tonal pitch relationships not based on chords? CHORD IS NOT ESSENTIAL. Tonality is the entire system that integrates the pitch group and is the availability of template matching by harmonics (including subharmonics) and the cognitive costs associated with it. (3) Is the

Post-Lewinnian Analysis

centering of relationships on a tonic pitch or triad an essential feature of tonality? NO.

Tonality is a system of two structures: a static structure (harmony, consonance) described by biophysically generated tetrahedral homology, and a dynamic structure (tonicity or its centricity) that binds it all together. In this sense, the atonal music of the twentieth century, developed under the well-defined structure of the twelve equal temperament, was rather a neutralisation of major and minor tonality in tonal music, as well as of the number zero found for positive and negative numbers, and should be regarded as the discovery of an approximation of the zeroth tonality within the tonal category. It is the perception of sounds that have no number-ratio relationship, such as rain, wind, thunder, etc., that should be called atonal music.

References

- Babbitt, Milton. 1961. "Set structure as a compositional determinant." *Journal of Music Theory*, 5/1: 72-94. <https://doi.org/10.2307/842871>
- Bigo, Louis, Antoine Spicher, Daniele Ghisi, and Moreno Andreatta. 2014. "Spatial transformations in simplicial chord spaces." In *Proceedings ICMC| SMC| 2014* (pp. 1112-1119).
- Bregman, Albert Stanley. 1994. *Auditory scene analysis: The perceptual organization of sound*. MIT press.
- Cadwallader, Allen, and David Gagne. 1998 *Analysis of Tonal Music: A Schenkerian Approach*. Oxford University Press.
- Capuzzo, Guy. 2006. "Pat Martino's The Nature of the Guitar: An Intersection of Jazz Theory and Neo-Riemannian Theory." *Music Theory Online* 12/1.
- Chahin, Rami. 2017. *Towards a spectral microtonal composition: a bridge between Arabic and Western Music*. Schott Music GmbH & Co. Kg / Schott Campus.
- Childs, Adrian P. 1998. "Moving beyond neo-Riemannian triads: Exploring a transformational model for seventh chords." *Journal of Music Theory*, 42/2: 181-193. <https://doi.org/10.2307/843872>
- Cohn, Richard. 1997. "Neo-Riemannian operations, parsimonious trichords, and their 'tonnetz' representations." *Journal of Music Theory*, 41/1: 1-66. <https://doi.org/10.2307/843761>
- Cohn, Richard. 1998. "Introduction to neo-Riemannian theory: a survey and a historical perspective." *Journal of Music Theory*, 42/2: 167-180. <https://doi.org/10.2307/843871>
- Cutting, Court B. 2018. "Microtonal Analysis of 'Blue Notes' and the Blues Scale." *Empirical Musicology Review*, 13/1-2: 84-99. <https://doi.org/10.18061/emr.v13i1-2.6316>
- Dahlhaus, Carl. 1990. *Studies on the origin of harmonic tonality*. Princeton University Press.
- Datta A. K., Sengupta R., and Dey N. 2011. "Objective analysis of srutis from the vocal performances of Hindustani music using clustering algorithm." *EUNOMIOS Open Online J. Theory Anal. Semiot. Music*, 25.

Post-Lewinnian Analysis

- Douthett, Jack. 2008. "Filtered point-symmetry and dynamical voice-leading." *Music Theory and Mathematics: Chords, Collections, and Transformations*, 72-106. <https://doi.org/10.1017/9781580467476.006>
- Douthett, Jack., and Peter Steinbach. 1998. "Parsimonious graphs: A study in parsimony, contextual transformations, and modes of limited transposition." *Journal of Music Theory*, 42/2: 241-263. <https://doi.org/10.2307/843877>
- Fétis, François-Joseph. 1844. *Traité complet de la théorie et de la pratique de l'harmonie contenant la doctrine de la science et de l'art*, Paris, Brandus.
- Fineberg, Joshua. 2000. "Spectral music." *Contemporary Music Review*, 19/2: 1-5.
- Forte, Allen. 1973. *The structure of Atonal Music*. Yale University Press
- Gollin, Edward. 1998. "Some aspects of three-dimensional 'Tonnetz'." *Journal of Music Theory*, 42/2: 195-206. <https://doi.org/10.2307/843873>
- Hook, Julian. 2007. "Cross-type transformations and the path consistency condition." *Music theory Spectrum*, 29/1: 1-39. <https://doi.org/10.1525/mts.2007.29.1.1>
- Koizumi, Fumio. 1958. *日本伝統音楽の研究 (Study of Japanese Traditional Music)*. Ongaku-no-tomo-sha.
- Krumhansl, Carol. L. 1983. "Perceptual structures for tonal music." *Music Perception*, 1/1: 28-62. <https://doi.org/10.2307/40285249>
- . 1998. "Perceived triad distance: Evidence supporting the psychological reality of neo-Riemannian transformations." *Journal of Music Theory*, 42/2: 265-281. <https://doi.org/10.2307/843878>
- Kubik, Gerhard. 2008. *Bourdon, blue notes, and pentatonicism in the blues; an Africanist perspective. Ramblin' on my mind: New perspectives on the blues*, Univ of Illinois Pr.
- Lewin, David. 1982. "A formal theory of generalized tonal functions." *Journal of Music Theory*, 26/1: 23-60. <https://doi.org/10.2307/843354>
- Mason, Laura Felicity. (2013). *Essential Neo-Riemannian Theory for Today's Musician*. Master's Thesis, University of Tennessee,
- McClimon, Michael. 2017. "Transformations in Tonal Jazz: ii-V Space." *Music Theory Online*, 23/1.
- Milne, Andrew. J., and Holland, Simon. 2016. "Empirically testing Tonnetz, voice-leading, and spectral models of perceived triadic distance." *Journal of Mathematics and Music*, 10/1: 59-85. <https://doi.org/10.1080/17459737.2016.1152517>

- Müller, Nora-Louise. 2020. *The Bohlen-Pierce Clarinet: Theoretical Aspects and Contemporary Applications*. BoD–Books on Demand.
- Ohgushi, Kengo. 1983. “The origin of tonality and a possible explanation of the octave enlargement phenomenon.” *The Journal of the Acoustical Society of America*, 73/5: 1694-1700. <https://doi.org/10.1121/1.389392>
- Polansky, Larry. 1985. “Interval Sizes in Javanese Slendro.” *Balungan*, 1/2: 9-11.
- Popoff, Alexandre, Moreno Andreatta, and Andréé Ehresmann. 2018. “Relational poly-Klumpenhower networks for transformational and voice-leading analysis.” *Journal of Mathematics and Music*, 12/1: 35-55. <https://doi.org/10.1080/17459737.2017.1406011>
- Rameau, Jean-Philippe. 1722. *Traité de l'harmonie réduite à ses principes naturels*. Paris.
- Riemann, Hugo. 1875. *Die objective Existenz der Untertöne in der Schallwelle*. Luckhardt.
- . 1891. *Katechismns der Akustik (Musikwissenschaft)* (No. 21). M. Hesse.
- . 1905. *Das Problem des harmonischen Dualismus*. CF Kahnt Nachf.
- Takahashi J. 2023a. “Power Series Template Matching Model for Pitch Perception.” BIORXIV/2023/525831
- . 2023b. “Subharmonic Template Matching in Hearing and Tonal Music.” <https://doi.org/10.51094/jxiv.479>
- Trainor, Laurel J. 2015. “The origins of music in auditory scene analysis and the roles of evolution and culture in musical creation.” *Philosophical Transactions of the Royal Society B: Biological Sciences*, 370/1664, 20140089. <https://doi.org/10.1098/rstb.2014.0089>
- Tymoczko, Dmitri. 2010. *A geometry of music: Harmony and counterpoint in the extended common practice*. Oxford University Press.
- Wiggins, Geraint A. 2012. “Music, mind and mathematics: Theory, reality and formality.” *Journal of Mathematics and Music*, 6/2: 111-123. <https://doi.org/10.1080/17459737.2012.694710>
- Zhuqing (Lester) S. Hu. 2021. “Chinese Ears, Delicate or Dull? Toward a Decolonial Comparativism.” *Journal of the American Musicological Society*, 74/3: 501–569. <https://doi.org/10.1525/jams.2021.74.3.501>

Tables and Figures

Table 1. Origin of the harmonics in the harmonic template: The harmonics N of the template are produced from the recursive matching of second and third signals with respect to the fundamental, where the numbers of their recursion are shown in the second and third columns. The third-order nonlinearity enables another matching via $2f_1 - f_2$ process. The fourth column shows the combination of harmonics used for the $2f_1 - f_2$ matching. (Takahashi 2023a)

N	2^n	3^m	$2f_1 - f_2$	N	2^n	3^m	$2f_1 - f_2$
1				14			$2*16-18$
2	1			15			$2*12-9$
3		1		16	4		
4	2			(17)			
5			$2*4-3$	18	1	2	
6	1	1		(19)			
7			$2*8-9$	20			$2*18-16, 2*16-12$
8	3			(21)			
9		2		(22)			
10			$2*9-8, 2*8-6$	(23)			
(11)				24	3	1	
12	2	1		...			
(13)							

Post-Lewinnian Analysis

Table 3. Perceptual distance between chromatic triad chords: Bold italics are the chord names. The pairs are aligned according to Milne,2016. Their pitch root notes are written in uppercase letters. The DoC orders of major-major and minor-minor distances are the same and consistent with the assumption of the competition between 3 and 5 accumulations, whereas those of major-minor and minor-major distances are not obvious. The exceptional proximity of *C_m-Eb* and *C-E_m* would be strong evidence of four-tone integration and Triad Root Equivalence.

Triad	Major-Major		Minor-Minor		Major-Minor		Minor-Major	
	Root	DoC	Root	DoC	Root	DoC	Root	DoC
<i>C-C</i>	C							
<i>C_m-C_m</i>			G					
<i>C_m-Eb</i>							G-Eb	(0,-1)
<i>C-E_m</i>					C-B	(1,1)		
<i>C-C_m</i>					C-G	(1,0)		
<i>C_m-F_m</i>			G	(-1,0)				
<i>C-F</i>	C	(-1,0)						
<i>C-F_m</i>					C-C	(0,0)		
<i>C_m-F</i>							G-F	(-2,0)
<i>C-E</i>	C	(0,1)						
<i>C_m-E_m</i>			G	(0,1)				
<i>C-Eb</i>	C	(1,-1)						
<i>C_m-E_{bm}</i>			G	(1,-1)				
<i>C-D_m</i>					C-A	(-1,1)		
<i>C-C_{#m}</i>					C-Ab	(0,-1)		
<i>C_m-D_m</i>			G	(2,0)				
<i>C-D</i>	C	(2,0)						
<i>C_m-D_b</i>							G-D _b	(2,1)
<i>C_m-E</i>							G-E	(-1,1)
<i>C_m-D_{bm}</i>			G	(-1,-1)				
<i>C-D_b</i>	C	(-1,-1)						
<i>C-F_{#m}</i>					C-D _b	(-1,-1)		
<i>C_m-D</i>							G-D	(1,0)
<i>C-E_{bm}</i>					C-B _b	(-2,0)		
<i>C_m-F_{#m}</i>			G	(2,1)				
<i>C-F_#</i>	C	(2,1)						

Post-Lewinnian Analysis

Table 4. Rational, Decimal, and Proximate normal form of tetrads: The pitch root notes are in boldface.

Chord name	Rational form				Decimal form				Proximate normal form			
dom7	1/1	5/4	3/2	9/5	4 1/7.2	5 1/4.8	6 1/5.76	7.2 1/4	4	5	6	7
m7b5	1/1	6/5	36/25	9/5	1/7.2 4	1/6 4.8	1/5 5.76	1/4 7.2	1/7	1/6	1/5	1/4
maj7#5	1/1	5/4	25/16	15/8	3.84	4.8	6	7.2	4	5	6	7
m(maj7)	1/1	6/5	3/2	15/8	1/7.2	1/6	1/4.8	1/3.84	1/7	1/6	1/5	1/4
maj7	1/1	5/4	3/2	15/8	4 1/7.5	5 1/6	6 1/5	7.5 1/4	4	5	6	-
min7	1/1	6/5	3/2	9/5	4 1/7.2	4.8 1/6	6 1/4.8	7.2 1/4	4	5	6	7

Post-Lewinnian Analysis

Table 5. Variations of four-tone integration of a diminished seventh chord: The pitch root notes are in boldface.

dim7	1/1	6/5	36/25	5/3
	C	E_b	F[#]	A
x1/3	6/2	7.2/2	4.32	5
x6	1/6	1/5	1/4.17	2/7.2
x1/4	4	4.8	5.76	6.67
x4	1/4	2/6.67	2/5.56	2/4.8
x1/5	5	6	7.2	2x4.17
x5	1/5	1/4.17	2/6.94	2/6
x1/7	7	2x4.2	2x5.04	2x5.83
x7	1/7	1/5.83	1/4.86	1/4.2

Post-Lewinnian Analysis

Table 6. Rational and Decimal form of a seventh suspended four chord.

7sus4	1/1	4/3	3/2	16/9
	C	F	G	Bb
x1/4	4	5.33	6	7.11
x16/3	1/5.33	1/4	2/7.11	2/6

Post-Lewinnian Analysis

Table 7. Relative pitches and intervals (in cents) of the Slendro scale, assigned by Polansky (1985) and modelled by the present work.

Tuning		I	II	III	V	VI	I'
Polansky	Tone	1	8/7	21/16	512/343	12/7	2
	Interval		231.2	239.6	222.7	239.6	266.9
{2,7}	Tone	1	8/7	343/256	49/32	7/4	2
	Interval		231.2	275.3	231.2	231.2	231.2

Post-Lewinnian Analysis

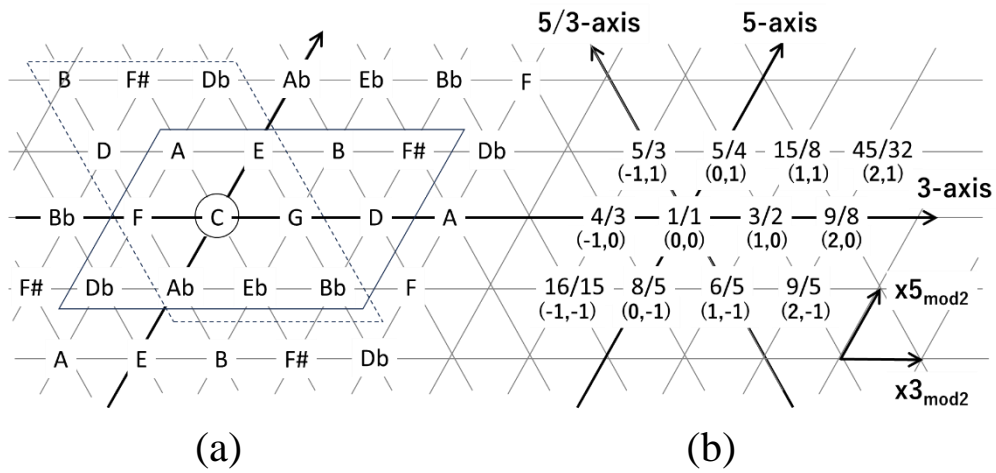

Figure 1. 12 tones of a chromatic scale and their numerical representation on Tonnetz:
 (a) Tonnetz and 12 chromatic tones. Various groupings are possible according to tuning (e.g. dotted area). (b) coordinate system in Rational form with C as the reference point. Lattice points are represented by relative frequencies $3^n 5^m$ that are folded within an octave by the power of 2. (n, m) denotes indices for the powers of 3 and 5.

Post-Lewinnian Analysis

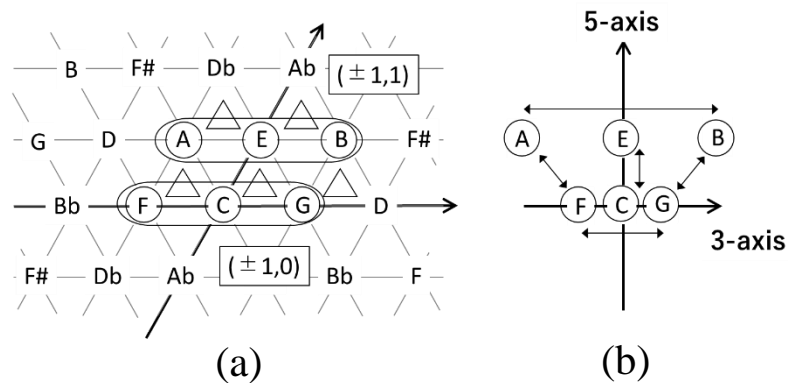

Figure 2. Positions of major triads on Tonnetz and the relative distance of their roots in perception: (a) positions and DoC of chords on Tonnetz. (b) chord distance map (Krumhansl, 1983; 1998) rotated according to the 3- and 5-axis. The distance measured on the 3-axis is leveraged for the shift on the 5-axis.

Post-Lewinnian Analysis

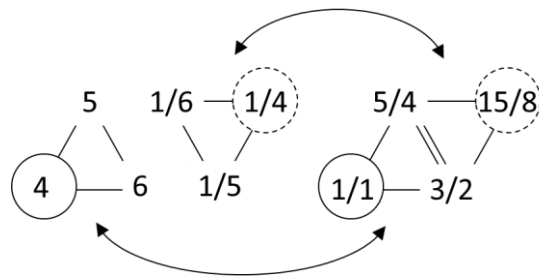

Figure 3. Triad Root Equivalence of the pair of major and minor triads: A major triad with a frequency ratio of 4:5:6 and a minor triad with 1/4:1/5:1/6 are integrated into pitches of missing fundamental=1, with a difference of semitone chroma and four octaves, making them difficult to separate perceptually, resulting in perception as if in unison. Solid and broken circles are the pitch root notes of the major and minor triads.

Post-Lewinnian Analysis

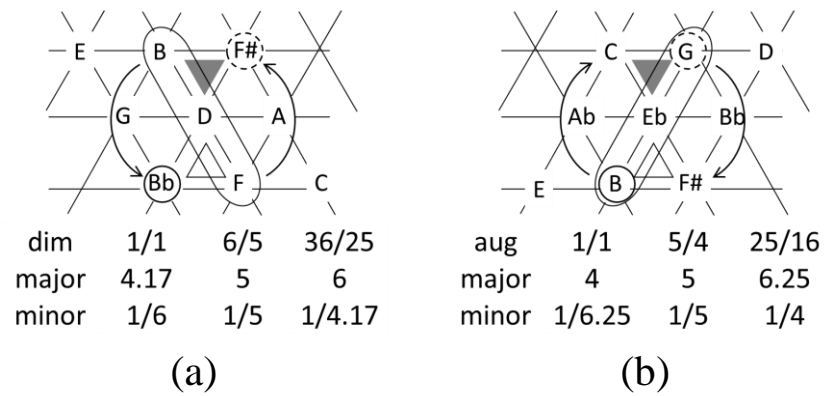

Figure 4. Approximation of diminished (a) and augmented (b) triads to major and minor triads on Tonnetz: Both chords have major and minor triads in the proximate normal form, which are represented by a fold of the endpoints of the straight line.

Post-Lewinnian Analysis

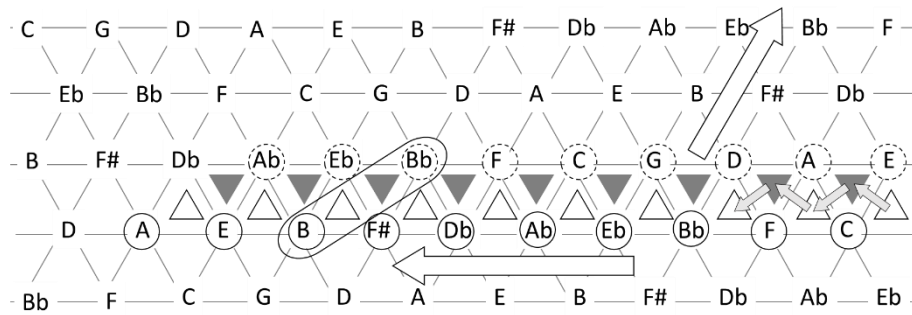

Figure 5. Pitch root motion of Beethoven's Ninth Symphony, mm 143-176: Chord progression is *C-A_m-F-D_m-Bb-G_m-Eb-C_m-Ab-F_m-Db-Bb_m-F#-Eb_m-B-Ab_m-E-Db_m-A*, which is written as a superposition of two series under Triad Root Equivalence (oval), (C-e)-(F-a)-(Bb-d)-(Eb-g)-(Ab-c)-(Db-f)-(F#-bb)-(B-eb)-(E-ab)-A and C-(f'-F)-(bb'-Bb)-(eb'-Eb)-(ab'-Ab)-(db'-Db)-(f#'-F#)-(b'-B)-(e'-E)-(a'-A). The former is a monotonous upward motion on the 5-axis with alternating timbre mode due to Triad Root Equivalence, and the latter is a monotonous negative motion on the 3-axis with alternating timbre mode.

Post-Lewinnian Analysis

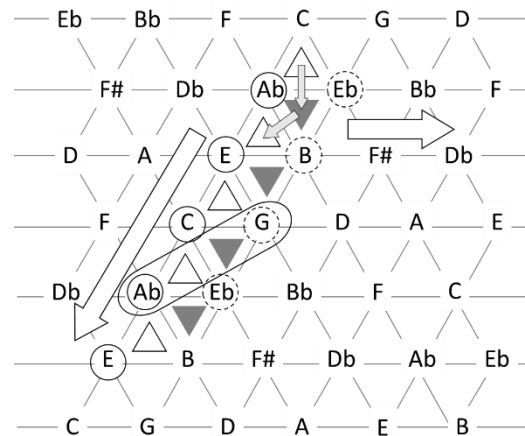

Figure 6. Pitch root motion of Brahms' Concerto for Violin and Cello, Op. 102, mm 270-178: Chord progression is $Ab-Ab_m-E-E_m-C-C_m-Ab-Ab_m-E$, which is written as a superposition of two series under Triad Root Equivalence (oval), $(Ab-eb)-(E-b)-(C-g)-(Ab-eb)-E$ and $Ab-(e'-E)-(c'-C)-(ab'-Ab)-(e'-E)$. The former is a monotonous positive motion on the 3-axis with alternating timbre mode due to Triad Root Equivalence, and the latter is a monotonous downward motion on the 5-axis with alternating timbre mode.

Post-Lewinnian Analysis

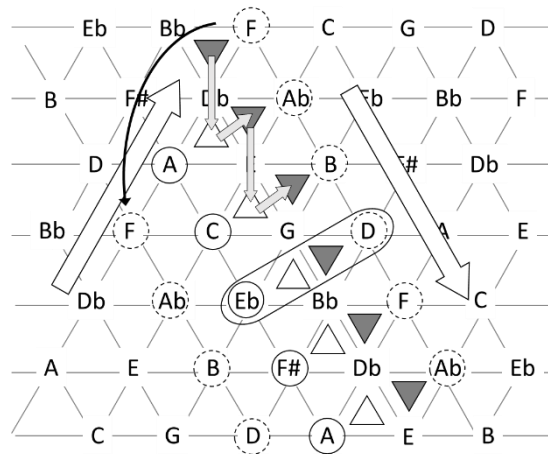

Figure 7. Pitch root motion of Liszt's Grande Fantaisie Symphonique für Klavier and Orchester, mm 185-199: Chord progression is ***Bb_m-A-Db_m-C-E_m-Eb-G_m-F#-Bb_m-A-Db_m***, which is written as a superposition of two series under Triad Root Equivalence (oval), (f-A)-(ab-C)-(b-Eb)-(d-F#)-(f-A)-ab and f-(Ab'-ab)-(B'-b)-(D'-d)-(F'-f)-(Ab'-ab). The former is a monotonous upward motion on the 5-axis with alternating timbre mode due to Triad Root Equivalence, and the latter is a monotonous downward motion on the 3/5-axis with alternating timbre mode.

Post-Lewinnian Analysis

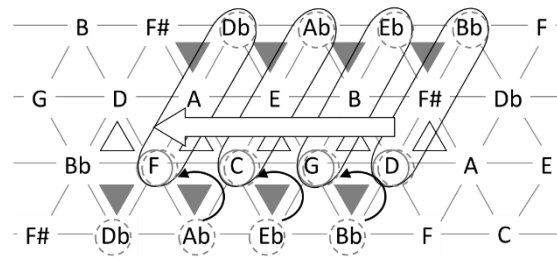

Figure 8. Pitch root motion of the opening of Take a Bow from Muse: Chord progression is $D-D_{aug}-G_m-G-B_{aug}-C_m-C-C_{aug}-F_m-F-F_{aug}-Bb_m$. The augmented chord is written as a superposition of the major and minor triads. The pitch root tone progression is written as a superposition of two series, $(D-f\#-d)-(G-b-g)-(C-e-c)-(F-a-f)$ and $D-(Bb-d-G)-(Eb-g-C)-(Ab-c-F)-(Db-f-bb)$. The former is a monotonous negative motion of three-tone groups on the 3-axis with a side trip on the 5-axis, and the latter is a monotonous negative motion of the cycles within minor triads on the 3-axis.

Post-Lewinnian Analysis

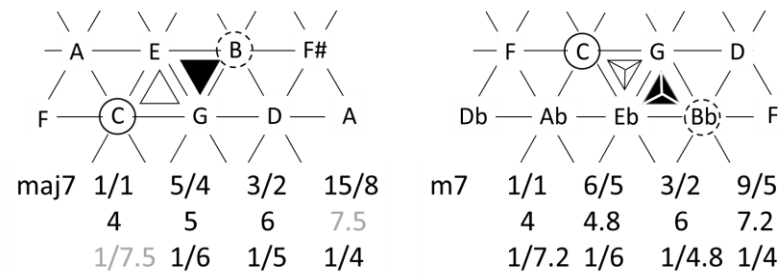

Figure 9. Equivalence of major-seventh and minor-seventh chords with proper triads and proper tetrads: The major-seventh chord is a superposition of major and minor triads, where the four-tone integration has a too large error, the pitch root tones of which are in unison under Triad Root Equivalence. The minor-seventh chord is approximated better by a major and a minor tetrad under four-tone integration.

Post-Lewinnian Analysis

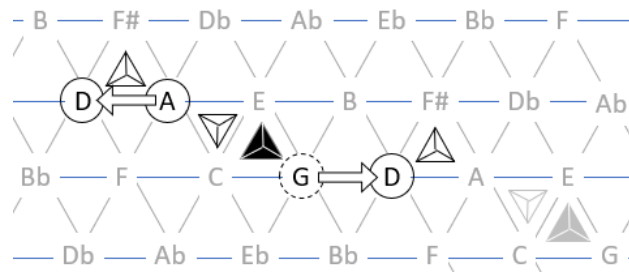

Figure10. Dual Entry Dominant System of II₇-V₇ chord: The min₇ chord has two pitch root notes at the root and seventh. The following dominant chord has the pitch root note that is connected with those of the min₇ chord by perfect fifth and perfect fourth, which provides dominant and subdominant progression paths.

Post-Lewinnian Analysis

No.	1	2	3	4	5	6	7	8	9	10	11	12	13	14
Chord	Bmaj7	D7	Gmaj7	Bb7	Ebmaj7	Am7	d7	Gmaj7	Bb7	Ebmaj7	F#7	Bmaj7	Fm7	Bb7
Pitch root 1	bb	D*	f#	Bb*	d	A*	D*	f#	Bb*	d	F#*	bb	F*	Bb*
Pitch root 2	B	D*	G	Bb*	Eb	g*	D*	G	Bb*	Eb	F#*	B	eb*	Bb*

	15	16	17	18	19	20	21	22	23	24	25	26
	Ebmaj7	Am7	D7	Gmaj7	C#m7	F#7	Bmaj7	Fm7	Bb7	Ebmaj7	C#m7	F#7
	d	A*	D*	f#	C#*	F#*	bb	F*	Bb*	d	b*	F#*
	Eb	g*	D*	G	b*	F#*	B	eb*	Bb*	Eb	b*	F#*

Figure 11. Dual pitch root note progression of Giant Steps implying the transformational structure: Each chord is broken into pitch root notes that can be connected by two continuous step-by-step paths on Tonnetz. The upper-case and lower-case letters represent major- (overtone) and minor-mode (undertone) timbre. Those with and without * represent the timbre of the four-tone and three-tone integration. The paths represent the chain of transformation of chords.

Post-Lewinnian Analysis

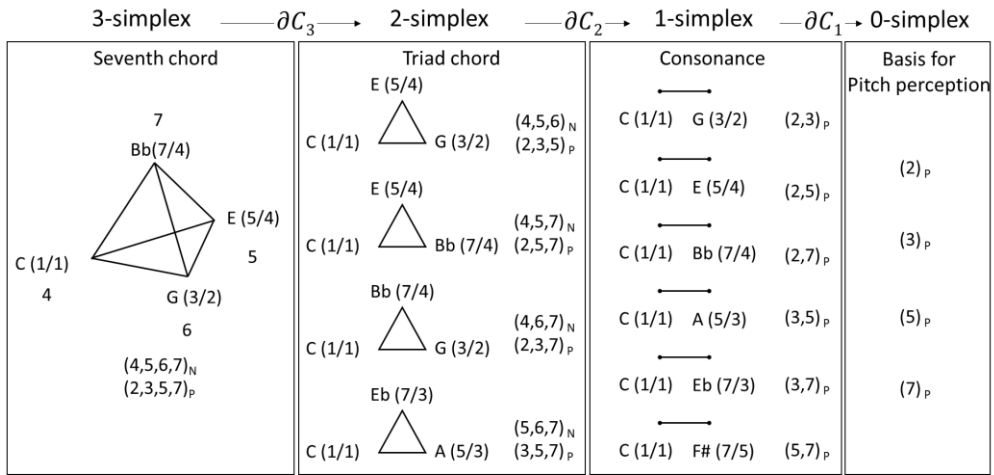

Figure 12. Homology of consonance relationships with a tonic C generated from the pitch group $\{2,3,5,7\}$: Each simplicial complex is integrated into a pitch. Numbers in the brackets adjacent to notes represent rational form. $(p_1, p_2, \dots)_N$ and $(p_1, p_2, \dots)_P$ represent the normal form and prime form. The notes Eb and Bb here are borrowed from the nearest tone in the 5-limit JI. They are known as blue notes.

Post-Lewinnian Analysis

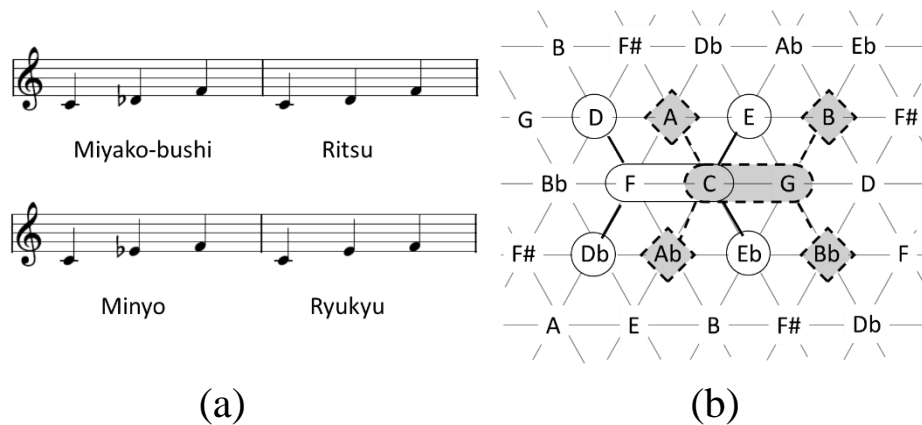

Figure 13. Koizumi's tetrachord units and their representation on Tonnetz: (a) Four Koizumi's tetrachord units consisting of common two nuclear tones separated by perfect fourth, C and F, and an intermediate tone between them with C as the reference note. The disjunction of tetrachords forms pentatonic scales. (b) Tone position of the tetrachord triads on Tonnetz. Shaded and broken tones represent the tetrachord disjunct to the original one. The intermediate tones are adjacent to one of the nuclear tones but are in a position where they do not undergo three-tone integration with the two nuclear tones.

Post-Lewinnian Analysis

The image shows a musical score for a lullaby in 7/8 time, consisting of two staves. The first staff contains the melody, and the second staff contains the accompaniment. Below each staff, chords are indicated in a specific notation: nuclear tones in parentheses, disjunct tones in brackets, and intermediate tones in plain text. The chords for the first staff are: A D E (FA), D E (FA), A (FA) (Bb A), and (F. The chords for the second staff are: A)(Bb D) (Bb A) (F E) D, (F E) D, (Bb A) D.

Example 1. Score of Lullaby of Itsuki village with grouping of Koizumi's tetrachords:

Koizumi's tetrachords are (A, Bb, D) with nuclear tones A and D, and an intermediate tone Bb. Its disjunct tetrachord is (E, F, A) with nuclear tones E, F, and an intermediate tone F. The intermediate tones act as a decoration of the nuclear tones and the root note progression becomes I-IV-V motion among A, D, and E.